

Chapter 4

Installation Instructions

How to Use these Instructions

These instructions guide you through the installation of a satellite system which includes your DishPro receiver (included with this manual), and a **DishPro** antenna system that can be identified by the DishPro logo shown below.



Connecting Your TV and VCR

Use the following diagram and instructions to connect the satellite receiver to a dish antenna, TV, and VCR (optional).

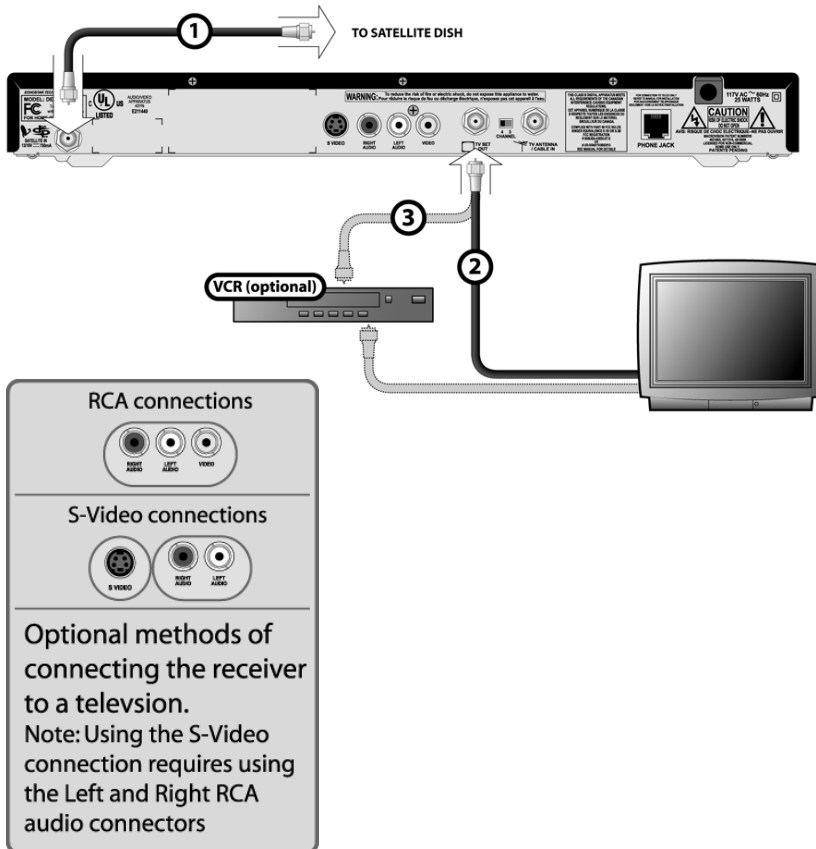

Tip: Using cable labels makes it easy to tell which cables connect to the receiver ports.

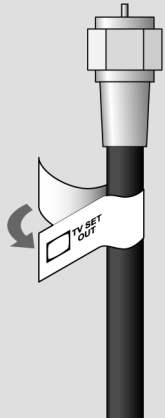

- 1 **Sat In** - Connect a coaxial cable between the DishPro LNBF and **SAT IN** on the back of the receiver. Peel off the blue sticker and affix it to the cable close to where it connects to the **SAT IN** connection on the back of the receiver.
- 2 **TV Set Out to a TV** - Connect a coaxial cable between the **TV SET OUT** on the receiver and the TV's input. Be sure to set the **CHANNEL 3/4** switch on the receiver to the channel you use to watch satellite TV. Peel off the white sticker and affix it to the cable close to where it connects to the **TV SET OUT** connection on the back of the receiver.
- 3 **TV Set Out to a VCR** (Optional) - Connect a coaxial cable between the **TV SET OUT** on the receiver and the VCR's input. Connect another cable between the VCR's output and the TV's input. Be sure to set the **CHANNEL 3/4** switches on the receiver and VCR to the channel you use to watch satellite TV.

Installing a DISH 500 Antenna

Note: If you have a Dish antenna system already installed, and the dish has been pointed for the strongest possible signal strength, you can skip this chapter and go directly to *Appendix A* to install the satellite receiver in an existing system.

The first step in installing your dish antenna is to assemble the satellite dish, mount it, and point it in the general direction of a satellite. To do this, follow these instructions:

Finding the Satellites

You need to find the satellites in the sky. To do this, you need to know the azimuth angle (the south, southeast, or southwest direction to the satellites) and the elevation angle (the angle up to the satellites) from your location, and the skew angle.

1. Make sure that the remote control batteries are fresh, and are installed properly. If needed, make sure that the remote is in **SAT** mode to control the satellite receiver.
2. Turn **ON** the television and receiver.

3. Display the **Point Dish and Signal Strength** menu by pressing MENU and then 6-1-1 (unless the receiver already displays this menu).

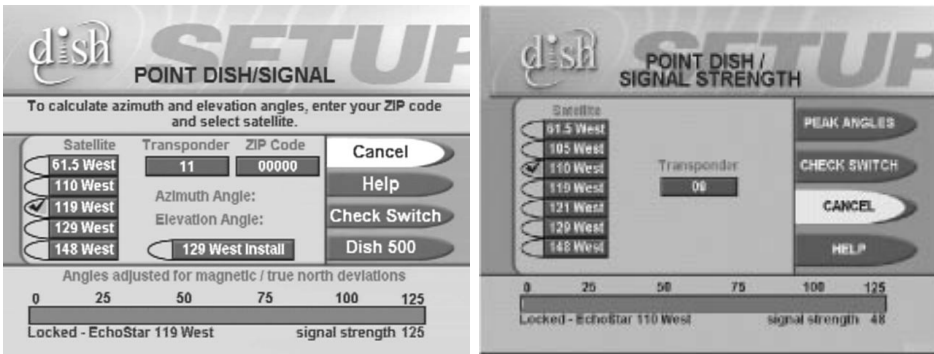

4. If your **Point Dish/Signal** screen looks like the one on the left, continue to step 6. If your Point Dish/Signal screen looks like the one on the right, select **Peak Angles**.
5. Enter your ZIP code in the **ZIP Code** field.
6. Select the **Dish 500** option.

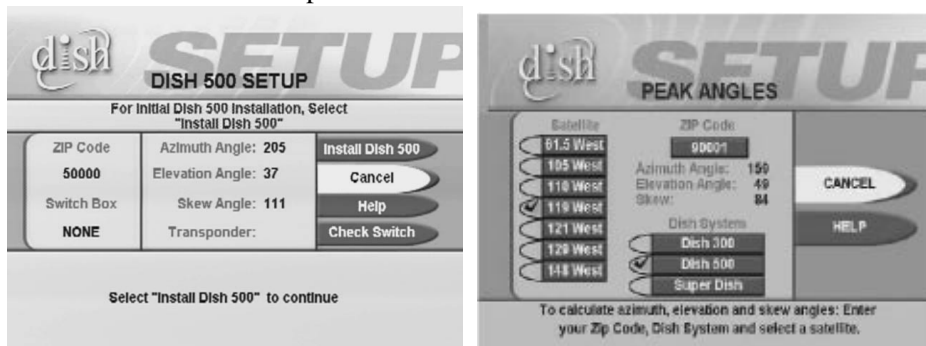

7. The menu displays the azimuth, elevation, and skew angles. Write down these numbers in the blanks provided in the margin.
8. Select **Cancel** to exit out of this menu and return to the **Point Dish/Signal** menu.
9. Go to *Mounting the Dish* on page 62.

Azimuth: _____

Elevation: _____

Skew: _____

Mounting the Dish

1. Using these azimuth and elevation angles, find a location for the satellite dish which can be pointed towards the satellites located at these angles. With a compass, find the required azimuth angle. Then, use the elevation angle to find out how high the satellites are in the sky from your location. Make sure nothing blocks the line of sight between the dish and the satellites.
2. Mount the mast to a solid surface so that the dish antenna cannot move or be bumped out of adjustment. Keep in mind that physical and environmental conditions can block your satellite dish's ability to receive a clear satellite signal. The conditions to be aware of are: Eaves and overhangs on your building or house, wind, plant growth, and deterioration of the mounting surface. Never mount to a tree.

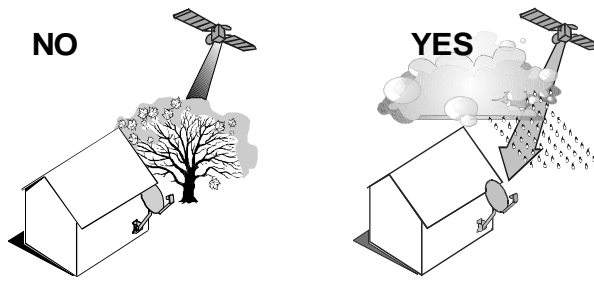

3. Align the top part of the mast so that it is absolutely vertical, as shown below. If the top part of the mast is off vertical by only a few degrees, it will be difficult or maybe even impossible for you to find the satellites. Take at least two readings with a bubble level, on the upper mast, that are 90 degrees apart from one another.

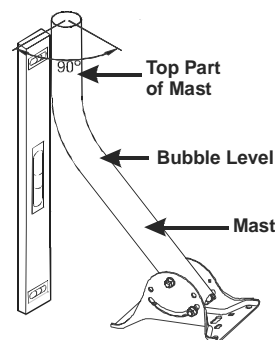

- Assemble the satellite dish as shown below, except do not attach the Y-bracket or LNBF at this time.

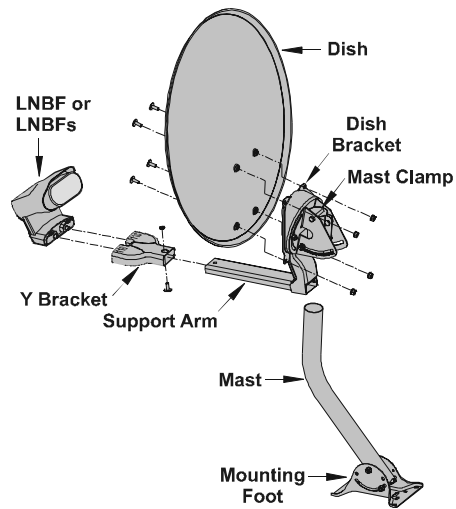

- Loosen both skew bolts and set the skew by rotating the dish mounting bracket to align the red mark with the required angle on the skew scale which you wrote down on 61. Tighten the skew bolts securely to keep the dish from rotating. **Once the skew is set, do not try to fine-tune this angle when aiming the dish.**

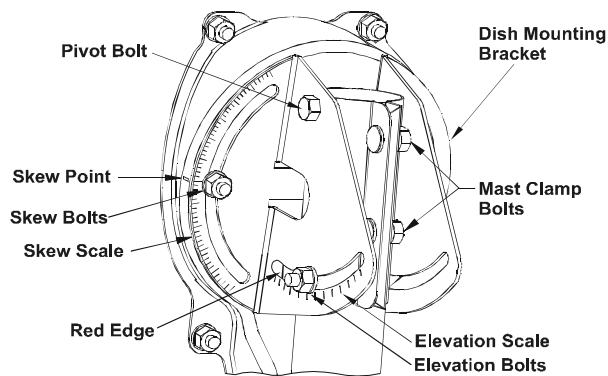

- Set the elevation by tilting the dish mounting bracket to align the red edge with the required angle from page 61 on the elevation scale. Tighten the elevation bolts, but *do not* tighten the pivot bolt at this time.

Note: You can have as much as 200 feet of cable between the DishPro LNBF and the DishPro receiver. However, you must use only RG-6 coaxial cables rated for 950 to 2150 MHz. Some cables may say "Swept tested for 2150 MHz." If you have any doubt about this, ask your DISH retailer, or look on the container the cable came in. Do not use cable company TV cables or cables from other satellite TV systems not rated for 950-2150 MHz. These other cables may cause signal loss. Do not use existing cables such as RG-59. Also, be sure that any outdoor connections are made using waterproof F-connectors.



Tighten all of the coaxial cable connection *only* by hand. If you use a wrench, you may over-tighten the connections and damage your equipment. Such damage is *not* covered by the Limited Warranty.

7. Thread the RG-6 coaxial cable through the mast support arm and the Y-bracket. This cable should be long enough to run from your receiver to your LNBF.

Note: See *Running Coaxial Cables* on page 77 for cable installation guidance.

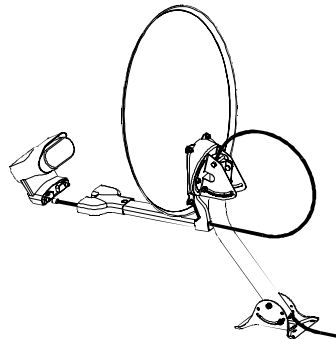

8. Attach the Y-bracket, using the Y-bracket screw.
9. Connect the RG-6 cable from the DISHPro **SAT IN** connection on the back of the receiver *directly to port 1* of the DISHPro Twin LNBF, as shown below. Be sure there are no multi-dish switches between the LNBF and the receiver.

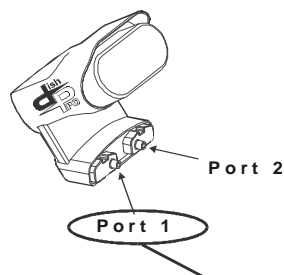

Connect to Port 1. It's on the left when the LNBF is pointed towards you

10. Attach the LNBF to the Y-bracket using the two LNBF screws.
11. Slide the dish assembly down onto the mast. Make sure the pivot bolt rests on the top of the mast. Turn the dish assembly so that it points in the general direction of the satellites, using the azimuth angle from 61.

- You should see the **Point Dish/Signal** menu. If not, open the **Main Menu**, select **System Setup**, then **Installation**, then **Point Dish/Signal** (press MENU and then press 6-1-1 on the remote).

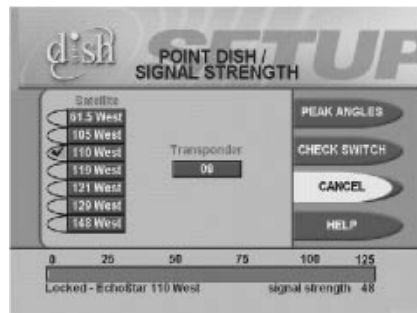
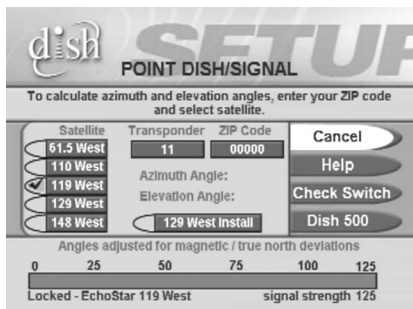

- Select **Check Switch**. The **Check Switch** screen will open.
- Select **Check** or **Test**. The receiver shows you a message that it is checking the switches.
- When the check switch procedure finishes, you will see an installation summary screen similar to the one below. In the **Satellite** line, you will see “Conn.” In the **Device** line, you will “Twin” twice. This indicates that your receiver has confirmed the connection with your DishPro Twin LNBF is working. The Transponder line may show two “Xs.” This is OK and does not indicate a problem with the receiver.



- Select **Cancel** or **OK** to return to the **Point Dish/Signal** screen. Make sure the check mark is next to **119 West**. If not, move the highlight to **119 West** and press SELECT. Notice the signal strength bar. This is used to help you aim the dish by showing the strength of the signal you are receiving. Look at the signal strength bar while you aim the dish. Don't stand in front of the dish while you aim it, because your body will block the satellite signal. After you adjust the aim, let go of the dish so that you can get a good signal reading after the dish settles back in place by itself. **Do not change the skew setting.**

Tip: Have one person aim the dish while another watches the signal strength or listens to the signal tone.

17. Turn the dish back and forth *very slowly*, until the signal strength bar turns *green*. This shows you've found the signal.

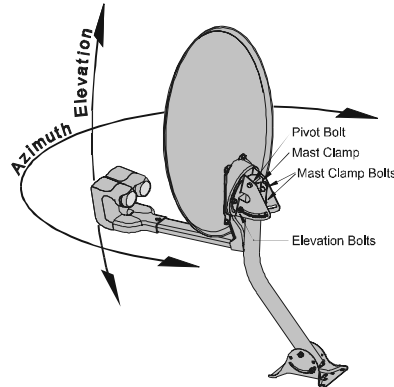

Note: If you cannot find the signal, turn the dish back to the first azimuth angle. Then, loosen both elevation bolts *just enough* so you can tilt the dish. Tilt the dish elevation up by two degrees, and then tighten both bolts. Now, turn the dish back and forth again. *If you still can't find the signal*, tilt the dish up again *very slightly* and turn the dish back and forth until you find the signal.

18. Once the signal strength bar is *green*, turn the dish back and forth *just a little*, to where the signal strength bar shows the strongest signal. When you find the strongest signal, tighten both mast clamp bolts. Then loosen both elevation bolts, *just enough* so you can tilt the dish. Tilt the dish up and down *just a little*, to where the signal strength bar shows the strongest signal. **Do not adjust the skew.** When you find the strongest signal, tighten all bolts in the dish assembly so the dish cannot be moved.
19. You are now ready to verify reception from both satellites. Select the **Check Switch** option. When the **Check Switch** menu opens, select **Check** or **Test**. The receiver shows you a message that it is checking the switches. When the procedure is finished, you will see an **Installation Summary** screen. This screen may look different than the one shown below. However, you *must* see that you have *signals from both* the **110 West** and **119 West** Satellites, you see "All" twice in the **Transponder** line, and the message "Satellite reception verified. Press CANCEL or OK to exit this menu."

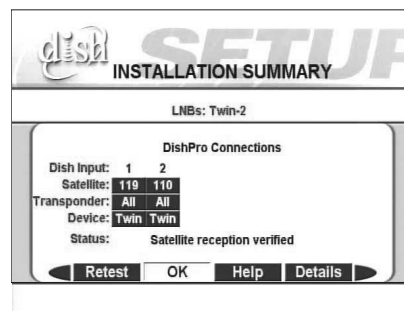

20. If you do not see “110” under **Dish Input 2**:
- Make sure the skew angle you wrote down on page 61 is exactly the same as the skew angle you set in step 5 on page 63. If it is not, reset the skew angle as described on page 63. After you reset the skew angle, go back page 65 and start over from step 16.
 - If “119” is shown under **Dish Input 2**, move the dish approximately 9° to the east and restart the procedure at step 12.
21. Look at the **Point Dish/Signal** menu. If you have good signal strength with the check mark in **119 West**, move the check mark to **110 West**. If you have good signal strength on **110 West**, go to step 22.
- If you do not have good signal strength with the check mark in **110 West**, go back to Step 17, and fine-tune the dish but with the check mark in **110 West** instead of **119 West**. While the 110 West and 119 West signals will not be equal, you should be able to fine-tune the dish until you have the strongest possible signal from both satellites.
22. Select Cancel to exit the **Point Dish/Signal** menu. An Attention screen will open asking the mounting and positioning of your dish is complete with a “Locked” indication in the Point Dish/Signals screen. If the answer is yes, select **Yes**.
- If the answer is **No**, you will need to repoint your dish following the preceding steps until the mounting and positioning is complete and you do have the “Locked” indication.*
23. After you select **Yes**, the receiver will begin taking a software upgrade. You will see a **Warning** that “Vital program information will now be downloaded into your receiver.” You will also see a status bar showing the progress of this upgrade.
24. Once the software upgrade is complete, you will see a message that your receiver’s memory is being upgraded.

Do not disturb the receiver while the receiver’s memory is being upgraded.

Note: If you are installing other DishPro receivers, be sure to run **Check Switch** on all of them, and allow them to take the necessary software upgrade.

Installing a Multiple Dish DishPro System

Note: You cannot use DishPro LNBFs and switches (those marked with the DishPro logo) with Legacy (non-DishPro) switches and LNBFs (those without the DishPro logo). You must install your DISH antenna system with either all DishPro LNBFs and switches or all Legacy LNBFs and switches. If you mix the two, the system will not work.

Note: You can have as much as 200 feet of cable between the DishPro LNBF and the DishPro receiver. However, you must use only RG-6 coaxial cables rated for 950 to 2150 MHz. Some cables may say "Swept tested for 2150 MHz." If you have any doubt about this, ask your DISH retailer, or look on the container the cable came in. Do not use cable company TV cables or cables from other satellite TV systems not rated for 950-2150 MHz. These other cables may cause signal loss. Do not use existing cables such as RG-59. Also, be sure that any outdoor connections are made using waterproof F-connectors.

Once you have installed the DISH 500 with its DishPro Twin LNBF using the preceding instructions, you can install a DISH 300 with a DishPro LNBF as follows:

1. Turn on the television and the receiver if they are not already on. You should see the **Point Dish/Signal** screen. If not, open the **Main Menu** and press 6-1-1 on the remote.

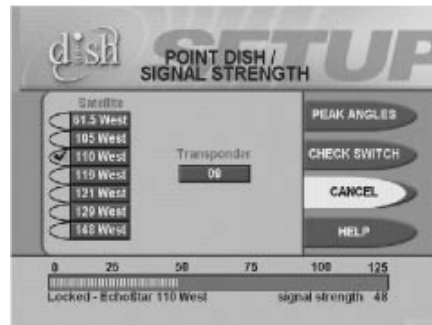
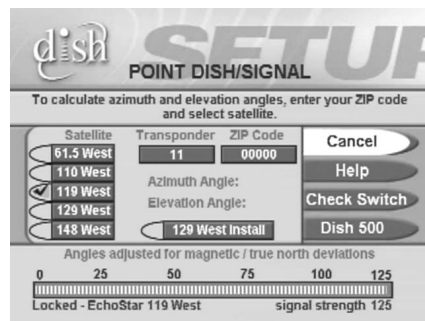

2. Make sure the check mark is next to the satellite your dish will be pointed toward.
3. If your **Point Dish/Signal** screen looks like the one on the left, continue to step 4. If your **Point Dish/Signal** screen looks like the one on the right, select **Peak Angles** and then select the **Dish 300** option.
4. Use the number buttons on the remote to enter your ZIP code to get the necessary azimuth and elevation. Write these numbers down in the spaces provided in the margin.
5. Mount the dish antenna following the mounting instructions that came with it.
6. Connect an RG-6 cable from the DishPro **SAT IN** connection on the receiver directly to the DishPro LNBF on the Dish 300. Make sure there are no multi-dish switches between the LNBF and the DishPro receiver.

Azimuth: _____

Elevation: _____

7. Select **Check Switch** from the **Point Dish/Signal** menu. When the **Check Switch** screen opens, select **Check**.
8. When **Check Switch** is complete, you will see an **Installation Summary** screen similar to the one shown next. It will show a connection (“Conn” next to satellite) and **Single** device under **1** (Dish Input). It may also show an **X** on the Transponder line. This is okay and does not mean there is a problem with the system.



9. Press CANCEL to exit back to the **Point Dish/Signal** menu.
10. Point the dish for the strongest possible signal, following the instructions that came with it and the DishPro wiring diagrams that start on page 70.
11. Connect any switches in your system, using the instructions which came with the switch(es).
12. Select **Check Switch** from the **Point Dish/Signal** menu. When the **Check Switch** menu opens, select **Check** or **Test**. When the procedure completes, you will see the **Installation Summary** screen again. This time you should see confirmation for all satellites your dishes are pointed at, and “Satellite reception verified.” You should also see that the switch(es) in your system has been correctly identified.
Refer to the DishPro wiring diagrams for examples of installation summary screens.
13. Press CANCEL to exit this menu, and then **Cancel** to exit the **Point Dish/Signal** screen. If you have any other receivers in your system, make sure you run **Check Switch** on each of them, and allow each to take the software upgrade, as needed.

DishPro Wiring Diagrams

DISH 500, One DishPro Twin LNBF, Two DishPro Receivers



This diagram leaves out grounding to be clear. Make sure you ground the system per the *National Electrical Code* (NEC) and all local electrical codes.

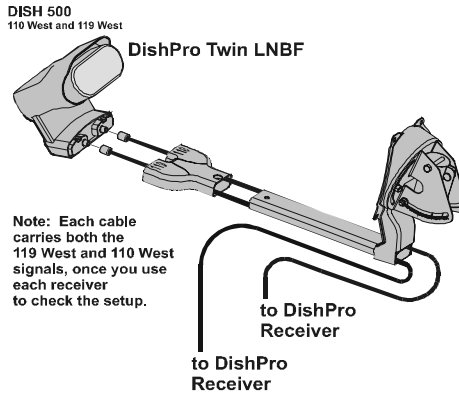

When you set up your system following this diagram and run **Check Switch** the **Installation Summary** screen should look similar to the one shown below.

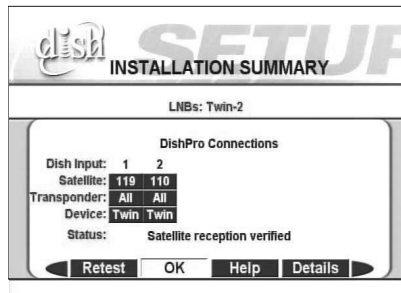

DISH 500, One DishPro Quad LNBF, Four DishPro Receivers



This diagram leaves out grounding to be clear. Make sure you ground the system per the *National Electrical Code* (NEC) and all local electrical codes.

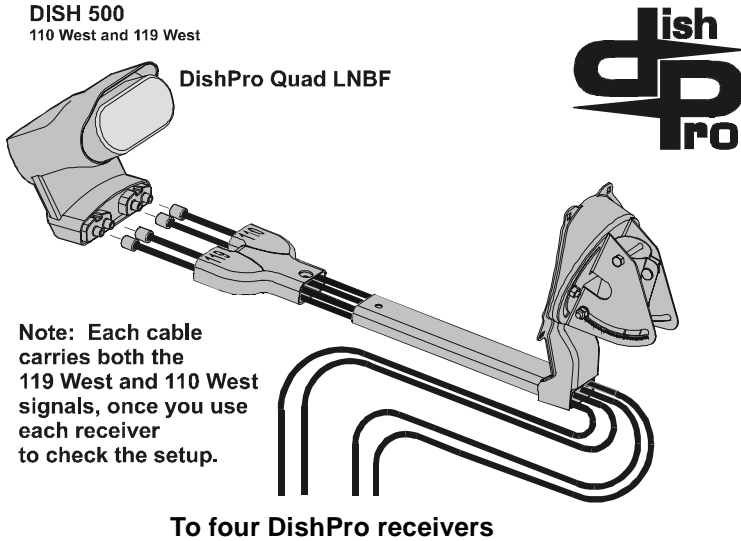

When you set up your system following this diagram and run **Check Switch** the **Installation Summary** screen should look similar to the one shown below.

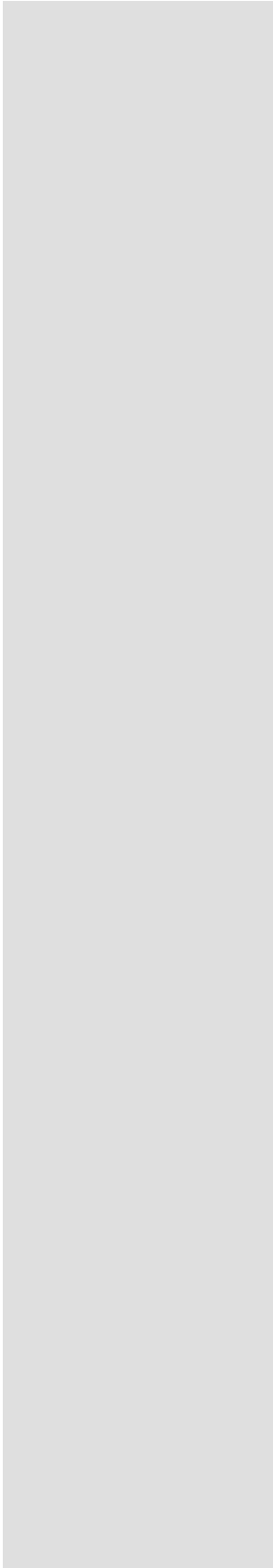
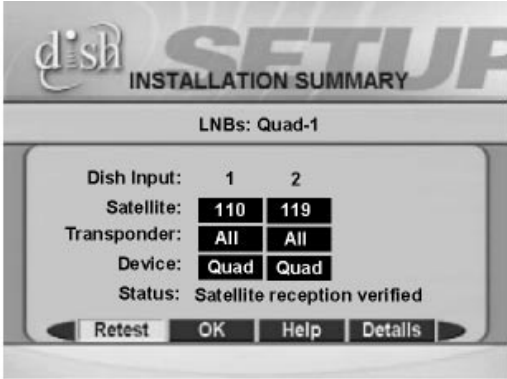

DISH 500 with a DishPro Twin LNBF, One DISH 300 with a DishPro LNBF, DP34 Switch, Four DishPro Receivers



This diagram leaves out grounding to be clear. Make sure you ground the system per the *National Electrical Code* (NEC) and all local electrical codes.

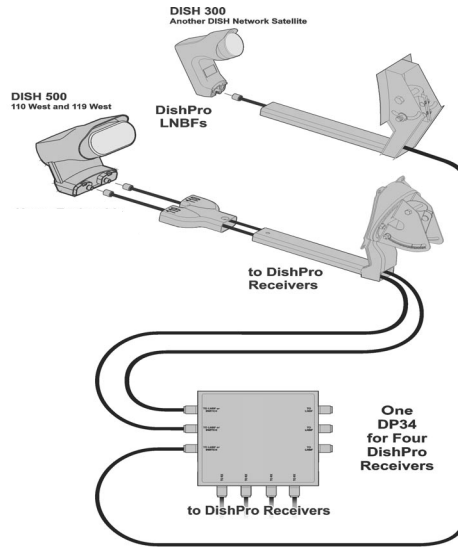

When you set up your system following this diagram and run **Check Switch** the **Installation Summary** screen should look similar to the one shown below.

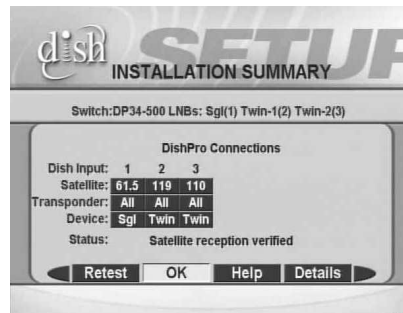

Two Dishes, Three Single-Output DishPro LNBFs, Three Cables, DP34 Switch, Four DishPro Receivers



This diagram leaves out grounding to be clear. Make sure you ground the system per the *National Electrical Code (NEC)* and all local electrical codes.

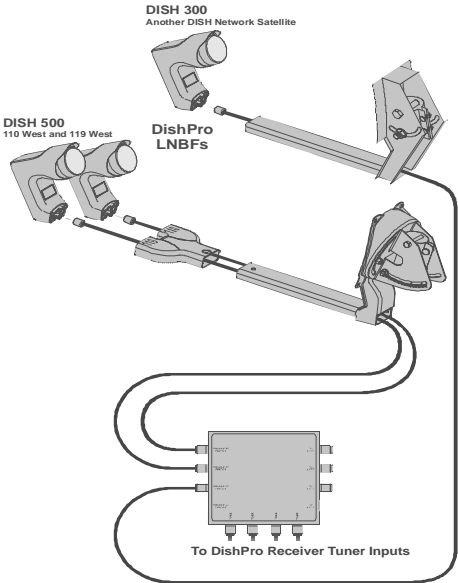

One DP34 for four DishPro receivers

When you set up your system following this diagram and run **Check Switch** the **Installation Summary** screen should look similar to the one shown below.

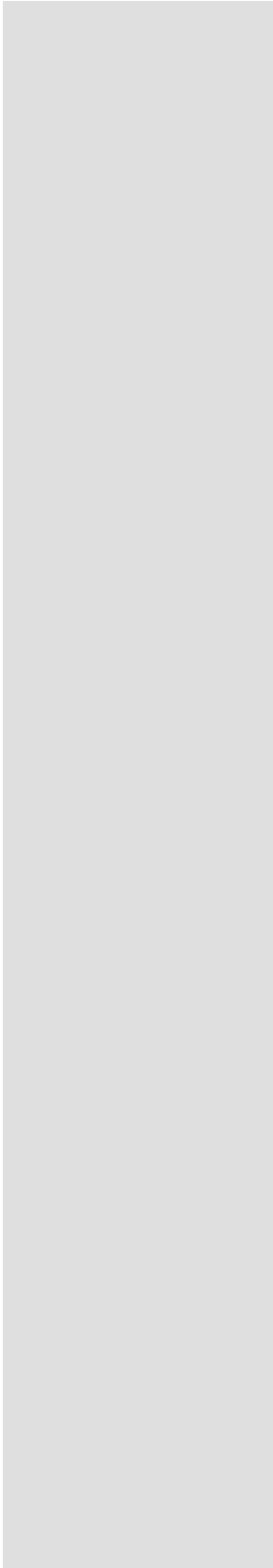
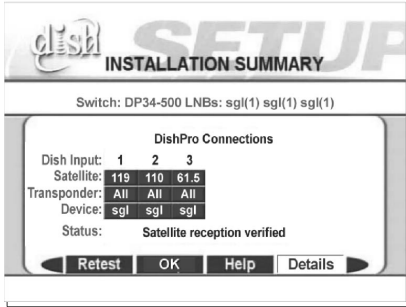

Two Dishes, One DishPro Twin LNBF, One DishPro Single LNBF, One DishPro Compliant Splitter, Two DishPro 2:1 Switches, Two Receivers



This diagram leaves out grounding to be clear. Make sure you ground the system per the *National Electrical Code* (NEC) and all local electrical codes.

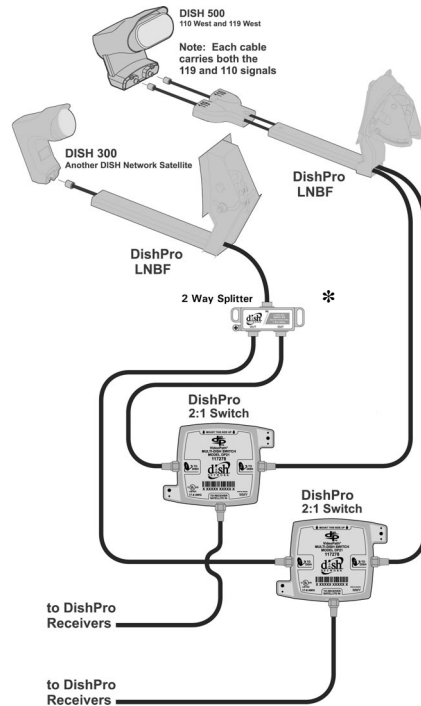

* When using a DishPro compliant splitter to split the signal from a DishPro single LNBF, the receiver whose DP21 switch is connected to the passing side of the splitter must be plugged into a live power outlet at all times. If not, the DishPro single LNBF will not have any power and will not be able to provide satellite signal to the other receiver.

When you set up your system following this diagram and run **Check Switch** the **Installation Summary** screen should look similar to the one shown below.



Two Dishes, Two DishPro Single LNBFs, Two DishPro Compliant Splitters, Two DishPro 21 Switches, Two Receivers



This diagram leaves out grounding to be clear. Make sure you ground the system per the *National Electrical Code* (NEC) and all local electrical codes.

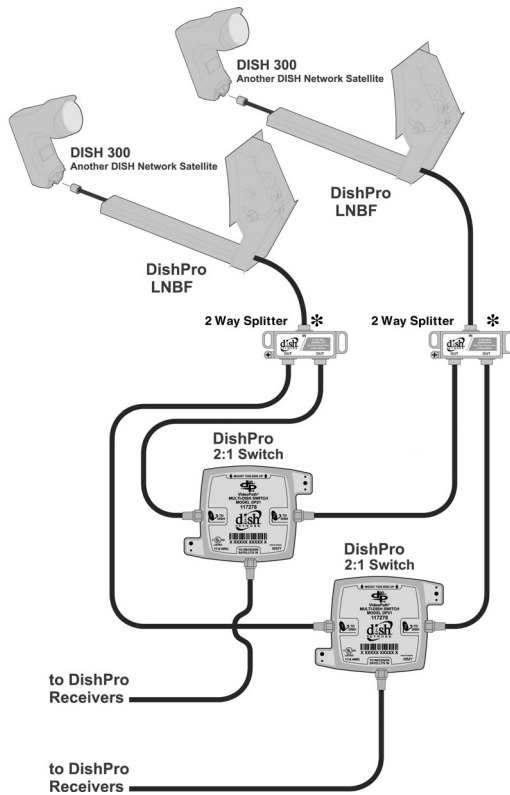

* When using a DishPro compliant splitter to split the signal from a DishPro single LNBF, the receiver whose DP21 switch is connected to the passing side of the splitter must be plugged into a live power outlet at all times. If not, the DishPro single LNBF will not have any power and will not be able to provide satellite signal to the other receiver.

When you set up your system following this diagram and run **Check Switch** the **Installation Summary** screen should look similar to the one shown below.



One DISH 500 with a DishPro Twin LNB, One DISH 300 with a DishPro Single LNB, and One DP21 Switch

This diagram leaves out grounding to be clear. Make sure you ground the system per the *National Electrical Code* (NEC) and all local electrical codes.

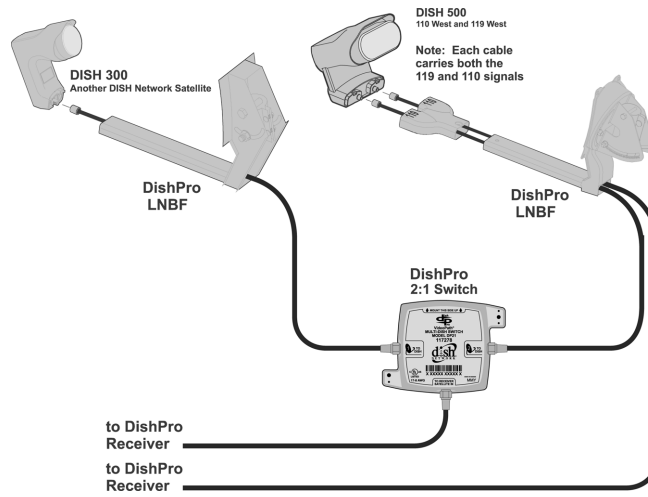

Note: This setup supports only one receiver from three satellite locations and the other receiver from only two satellite locations.

Running Coaxial Cable

- Using the shortest path possible, run the coaxial cable(s) from the ground block or switch to the satellite receiver(s). Do *not* kink or pinch any cable. Cables should be bent *only* in gentle curves.



Do *not* use a longer cable between the satellite dish and the receiver than is specified in the DishPro or Legacy system installation instructions. If your system requires more cable than the limit specified in these installation instructions, you should consider having the system professionally installed.

- Put a drip loop in each cable at a point before it enters the building. A drip loop allows moisture to drip from the cable before it runs into the building.

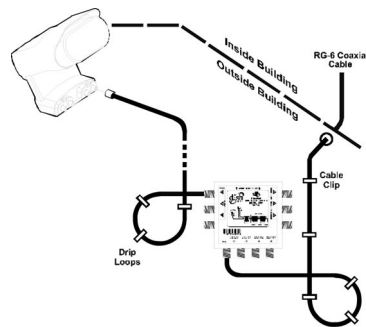

FOR EXAMPLE ONLY



Before drilling any holes in the wall or roof of your building, make sure that there are no wires or pipes in the area of the holes. If you are not comfortable doing this, contact a professional in your area. Make sure that you follow all safety instructions and building codes.

- Locate each receiver inside the building, against or near an outside wall. Then drill a hole through the outer wall to pass a cable inside the building. If a receiver is located in an interior room, run a cable through the outside wall, and into an attic, basement, or crawl space in order to reach the receiver.
- Seal all holes that you drill in the building with silicone or other weather-proof sealant after installation. Once each cable is inside the building, you may attach it to a wall receptacle or directly to a receiver.



Tighten the back panel coaxial cable connections *only* by hand. Using a wrench may over-tighten the connections, causing damage. Such damage is *not* covered by the Limited Warranty in the *User Guide* that came with the system.

Connecting Each Receiver to a Phone Line

You *must* keep each receiver connected to an active telephone line. Otherwise, you may not be able to order pay per view programs or use all of the Dish Interactive features. Run a telephone cable with a standard RJ-11 connector from each receiver's back panel **PHONE JACK** to an active telephone connection.

Note: You *may* be able to use a wireless telephone extender. However, this may *not* support all the features of some receivers, such as Caller ID.

Note: If you have a Digital Subscriber Line (DSL), you may have to install a DSL filter between the receiver's back panel **PHONE JACK** and the telephone wall jack to successfully connect with the DISH Network. You can obtain a filter from your DSL provider.

You *must* also set up each receiver for your telephone system (touchtone or rotary/pulse), and set a telephone number prefix, if you need a prefix to make an outside call.

1. Display the **Installation and Setup** menu (press **MENU** then 6-1-4).
2. Select the **Telephone System** option to display the **Telephone System Setup** menu.



3. Select the **Touch Tone** or the **Rotary/Pulse** option in the **Phone Type** list.

Note: Usually, you need a telephone number prefix only for business installations. For most residential installations, all you need to do is set the telephone system type. The default setting of **No Prefix needed** will allow correct dialing. If this is the case, select the **Save** option to save the above setting, and stop here. If you do need to set a prefix, then instead of selecting the **Save** option, go on to step 4.

4. Move the highlight to the **Outside Line Prefix** list. Press the **SELECT** button to select the highlighted option.

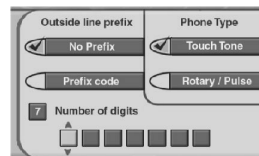

5. Select one of the following:
 - If you do not need to dial a prefix, select the **No Prefix** option.
 - If you need to dial a prefix (for example, dial 9 to get an outside line), select the **Prefix Code** option. The receiver displays the same number of boxes (highlighting the first box) where you must enter the digits. Use the Number Pad to enter the prefix code. As you enter each number, the highlight moves to the next box.
6. Move the highlight to the **Save** option. Press the **SELECT** button to save the settings.

Notes

